

特殊U字溝

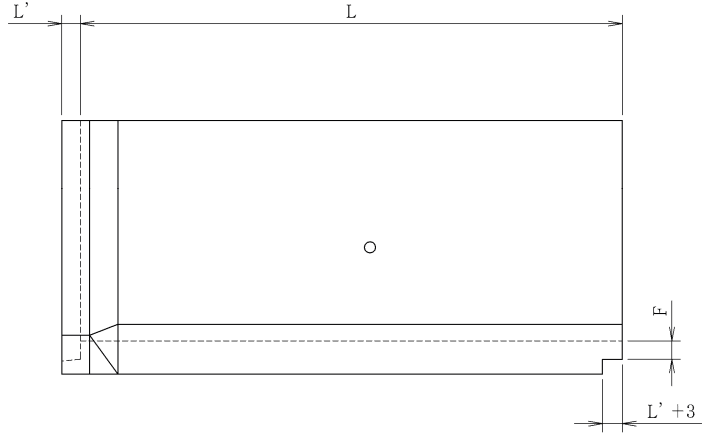
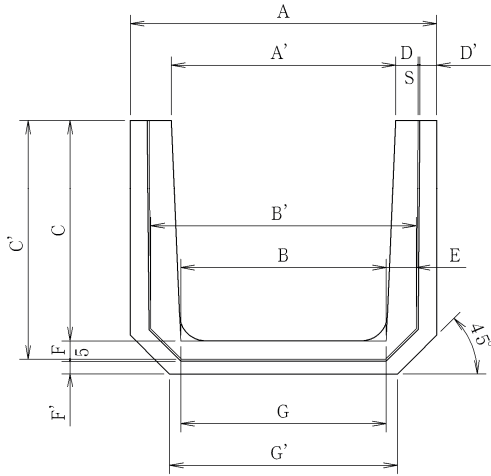

呼び名	寸法 (mm)								ソケット部寸法 (mm)								参考重量 (kg)
	A	B	C	D	E	F	G	L	A'	B'	C'	D'	F'	G'	L'	S	
200	200	180	200	35	40	25	175	2000	340	260	225	30	25	220	50	5	138
250	250	230	250	45	50	30	215	2000	410	330	280	30	30	250	50	5	202
300	300	260	300	50	65	40	245	2000	480	390	340	35	30	310	50	5	288
350	350	300	350	50	70	40	285	2000	540	440	390	40	30	350	50	5	337
400	400	350	400	55	75	40	335	1500	610	500	440	45	35	400	50	5	301
450	450	400	450	55	75	45	395	1500	660	550	495	45	35	460	50	5	339
500	500	450	500	55	75	45	445	1000	710	600	545	45	35	510	50	5	254
600	600	550	600	60	80	50	545	1000	820	710	650	45	35	610	50	5	319