

# マンホール側塊

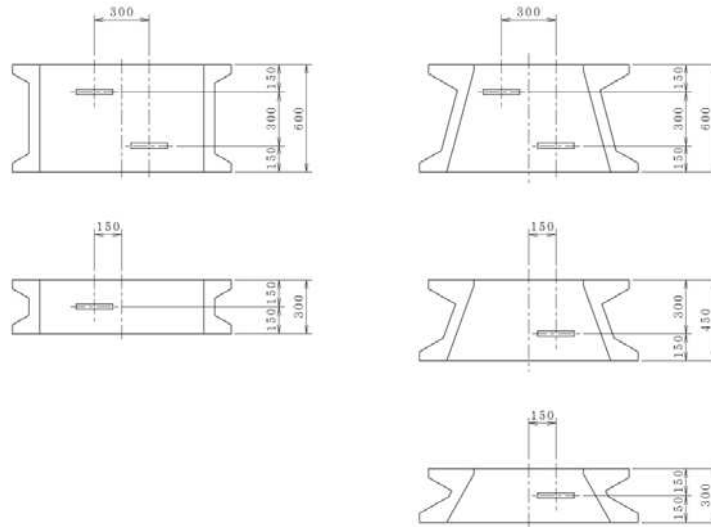
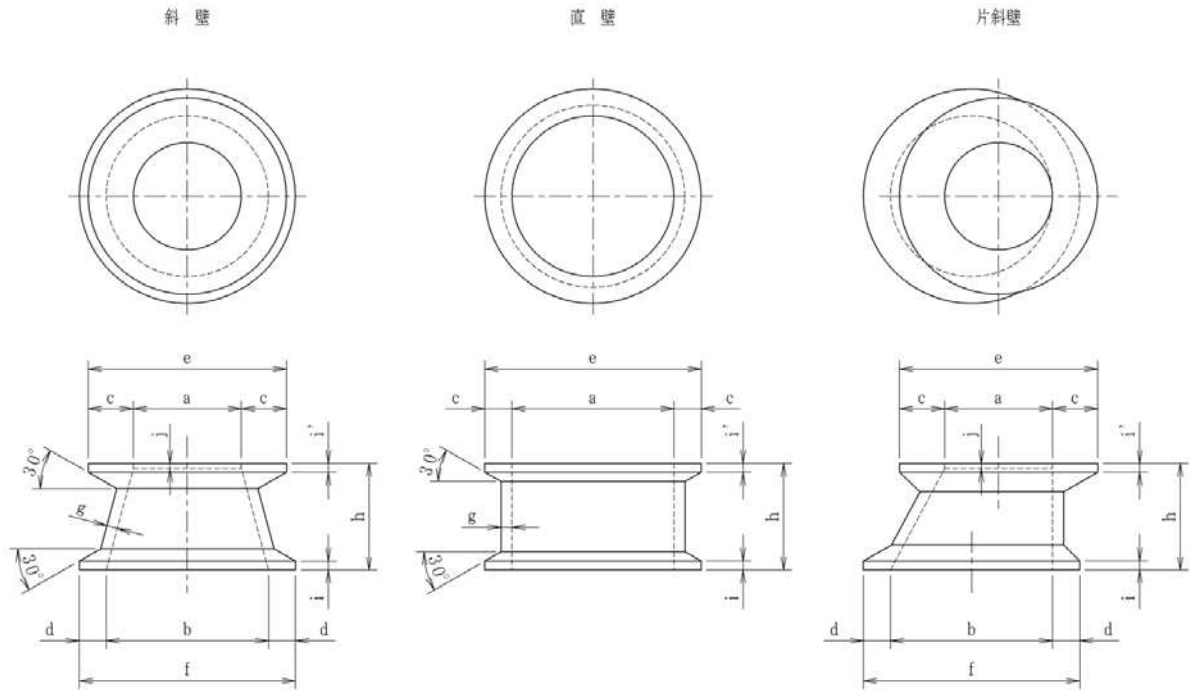

種類	寸法 (mm)												参考重量 (kg)
	呼び	a	b	c	d	e	f	g	h	i	i'	j	
斜 壁	600A	600	900	250	150	1100	1200	60	300	50	60	30	318
	600B	600	900	250	150	1100	1200	60	450	50	60	30	370
	600C	600	900	250	150	1100	1200	60	600	50	60	30	423
	600D	600	1200	250	150	1100	1500	70	600	50	60	40	539
直 壁	900A	900	—	150	—	1200	—	60	300	50	50	—	244
	900B	900	—	150	—	1200	—	60	600	50	50	—	374
	1200A	1200	—	150	—	1500	—	70	300	50	50	—	326
	1200B	1200	—	150	—	1500	—	70	600	50	50	—	527
	1500A	1500	—	150	—	1800	—	80	300	50	50	—	414
	1500B	1500	—	150	—	1800	—	80	600	50	50	—	700
片面斜壁	600A	600	900	250	150	1100	1200	60	300	50	60	30	275
	600B	600	900	250	150	1100	1200	60	450	50	60	30	349
	600C	600	900	250	150	1100	1200	60	600	50	60	30	381
	600D	600	1200	250	150	1100	1200	70	600	50	60	30	622